

TOLERANCES
UNLESS NOTED

2 PLACE	+/- .015
3 PLACE	+/- .010
ANGLES	+/- 2°

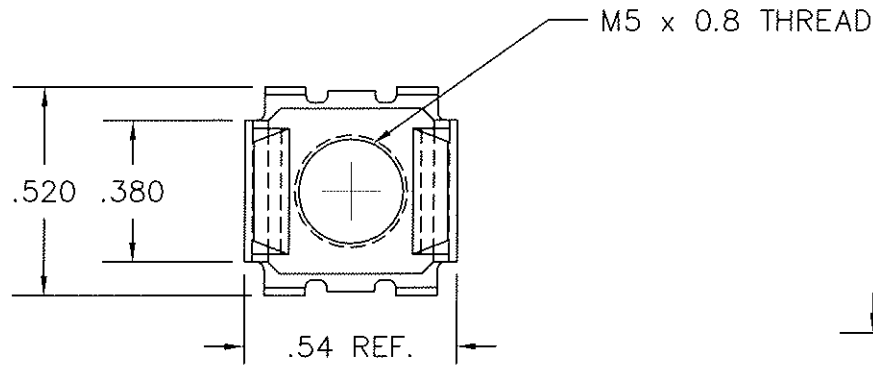

TYPICAL APPLICATION

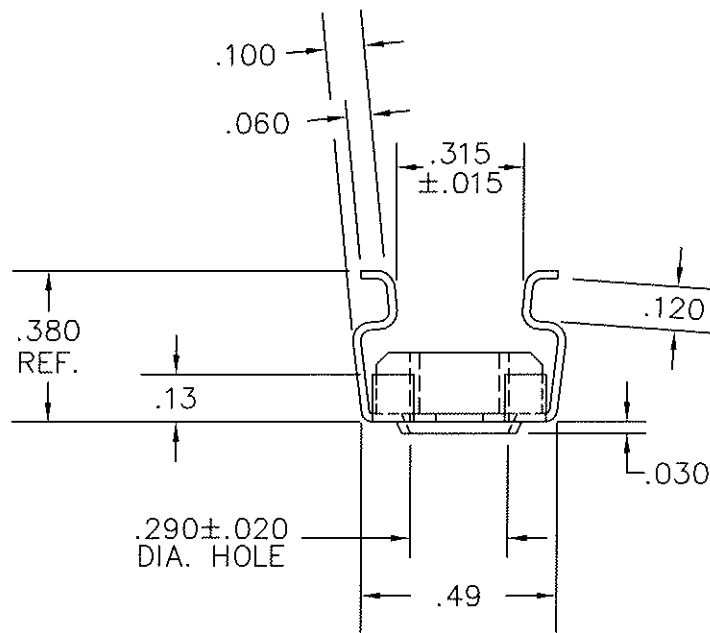
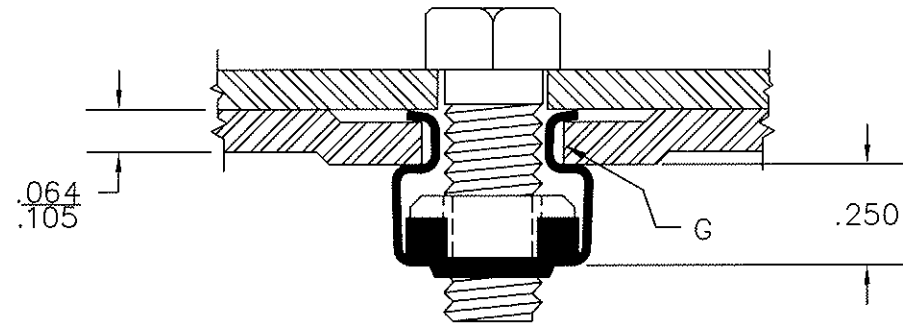

G MOUNTING HOLE

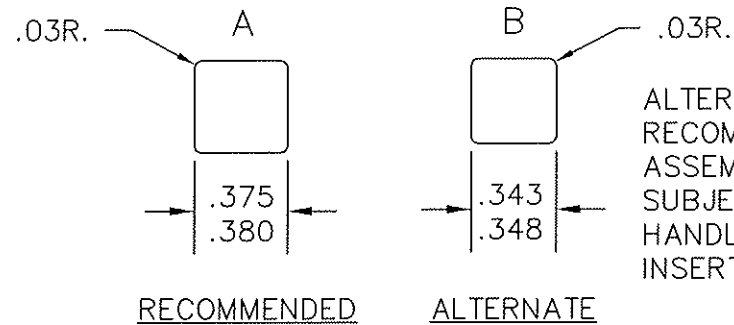

ALTERNATE HOLE LAYOUT
RECOMMENDED WHERE
ASSEMBLY WILL BE
SUBJECT TO EXCESSIVE
HANDLING PRIOR TO
INSERTION OF SCREW

NOTES: 1. M508 & .064 TO APPEAR ON SURFACE OF PART.
② .105

2. FINISH: ZINC PLATE & TRIVALENT CLEAR CHROMATE

Stay Online

SCALE: 2 TIMES

DRAWN BY: SJZ

DATE: 24 AUG 01

CAD FILE:

Item #6543 Cage Nut Snap In/1 M5

MATERIAL: .020 THK. SPRING STEEL

DRAWING NUMBER